

**Manufacturer • Fabricant • Producent  
Producător • Fabricante:**  
**UK Manufacturer:**  
Kingfisher International Products Limited,  
3 Sheldon Square, London, W2 6PX,  
United Kingdom

**EU Manufacturer:**  
Kingfisher International Products B.V.  
Rapenburgerstraat 175E  
1011 VM Amsterdam  
The Netherlands  
[www.kingfisher.com/products](http://www.kingfisher.com/products)

**EN** [www.diy.com](http://www.diy.com)  
[www.screwfix.com](http://www.screwfix.com)  
[www.screwfix.ie](http://www.screwfix.ie)

**To view instruction manuals online,  
visit [www.kingfisher.com/products](http://www.kingfisher.com/products)**

**FR** [www.castorama.fr](http://www.castorama.fr) [www.screwfix.fr](http://www.screwfix.fr)  
[www.bricodepot.fr](http://www.bricodepot.fr)

**Pour consulter les manuels d'instructions  
en ligne, rendez-vous sur le site  
[www.kingfisher.com/products](http://www.kingfisher.com/products)**

**PL** [www.castorama.pl](http://www.castorama.pl)

**Aby zapoznać się z instrukcją obsługi online,  
odwiedź stronę [www.kingfisher.com/products](http://www.kingfisher.com/products)**

**RO** [www.bricodepot.ro](http://www.bricodepot.ro)

**Pentru a consulta manualele de instrucțiuni  
online, vizitați [www.kingfisher.com/products](http://www.kingfisher.com/products)**

**ES** [www.bricodepot.es](http://www.bricodepot.es)

**Para consultar los manuales de instrucciones  
en línea, visite [www.kingfisher.com/products](http://www.kingfisher.com/products)**

**PT** [www.bricodepot.pt](http://www.bricodepot.pt)

**Para consultar manuais de instruções online,  
visite [www.kingfisher.com/products](http://www.kingfisher.com/products)**

**TR** **İthalatçı Firma:**

KOÇTAŞ YAPI MARKETLERİ TİC. A.Ş.  
Taşdelen Mah. Sırrı Çelik Bulvarı No:5  
34788 Taşdelen/Çekmeköy/İSTANBUL  
Tel: +90 216 4300300  
Faks: +90 216 4844313  
[www.koctas.com.tr](http://www.koctas.com.tr)

**Kullanım kılavuzuna internet üzerinden ulaşmak  
için [www.kingfisher.com/products](http://www.kingfisher.com/products) adresini  
ziyaret edin**

Yetkili servis istasyonları ve yedek parça temini için  
aşağıda yer alan Koçtaş Müşteri Hattı ve Koçtaş  
Genel Müdürlük irtibat bilgilerinden faydalanınız.

KOÇTAŞ MÜŞTERİ HİZMETLERİ  
0850 209 50 50

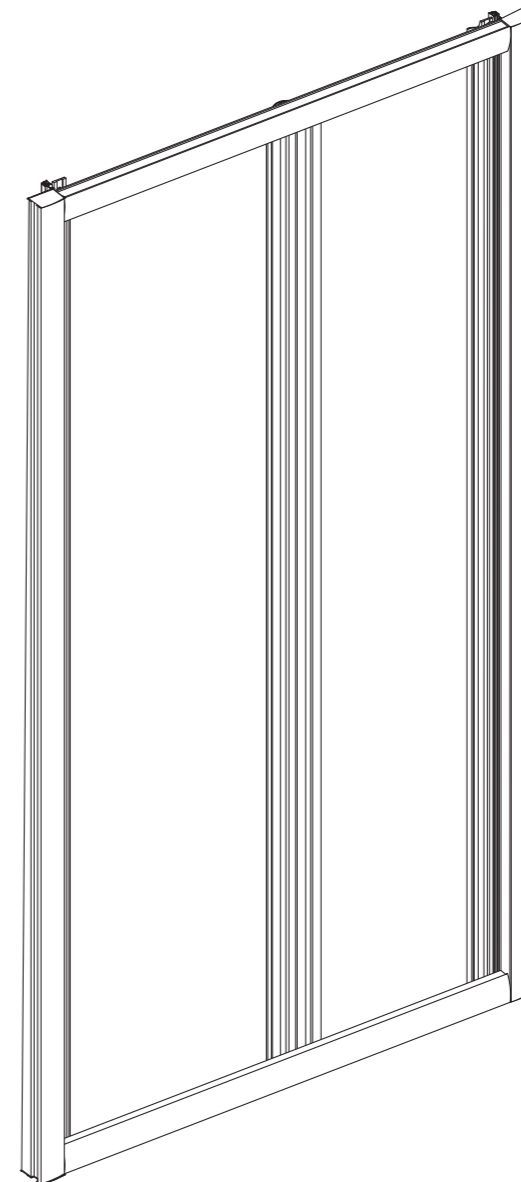

**COOKE™  
&LEWIS**

**3663602951704 / 3663602951711 / 3663602944362 / 3663602944386  
3663602944379 / 3663602944393**

# Onega



**EN** IMPORTANT - Please read carefully the separate safety guide before use.

**FR** IMPORTANT - Lire attentivement le guide de sécurité séparé avant utilisation.

**PL** WAŻNE - Przed użyciem proszę dokładnie zapoznać się z instrukcją bezpieczeństwa.

**DE** WICHTIG - Bitte lesen sie die separaten sicherheitsanweisungen vor gebrauch.

**RUS** ВАЖНО - Пожалуйста, внимательно прочитайте отдельное руководство по технике безопасности перед использованием.

**RO** IMPORTANT - Vă rugăm să citiți cu atenție ghidul de siguranță separat înainte de utilizare.

**ES** IMPORTANTE - Lea atentamente la guía de seguridad separado antes de utilizar.

**PT** IMPORTANTE - Leia atentamente o guia de segurança separado antes de usar.

**TR** ÖNEMLI - Kullanmadan önce emniyet kurallarını lütfen dikkatle okuyun.

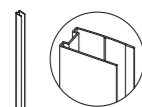
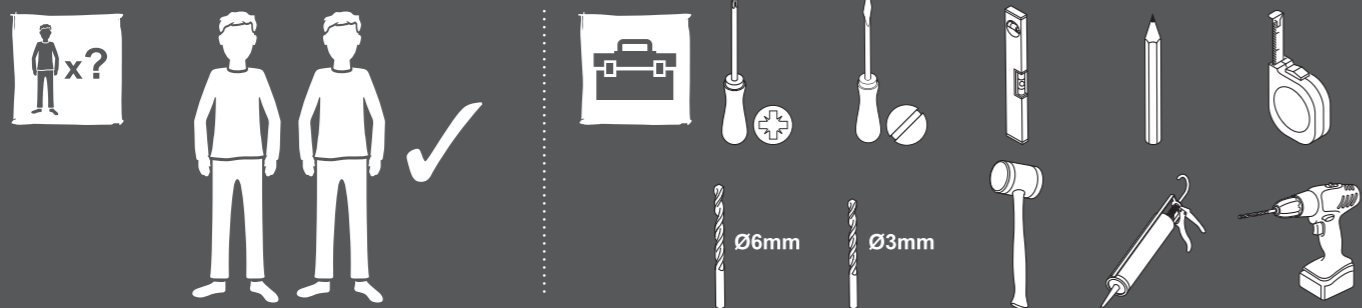

[01] x 2

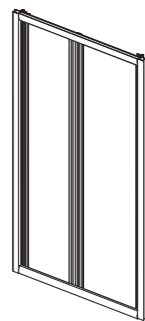

[02] x 1

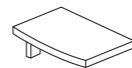

[03]a x 1

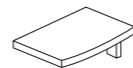

[03]b x 1

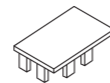

[04] x 2

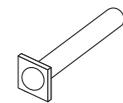

[05] x 1



[06]a x 6



[06]b x 6

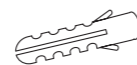

[07] x 6



[08] x 3



[09] x 6 (ST4 x 35mm)



[10] x 6 (ST3.5 x 8mm)

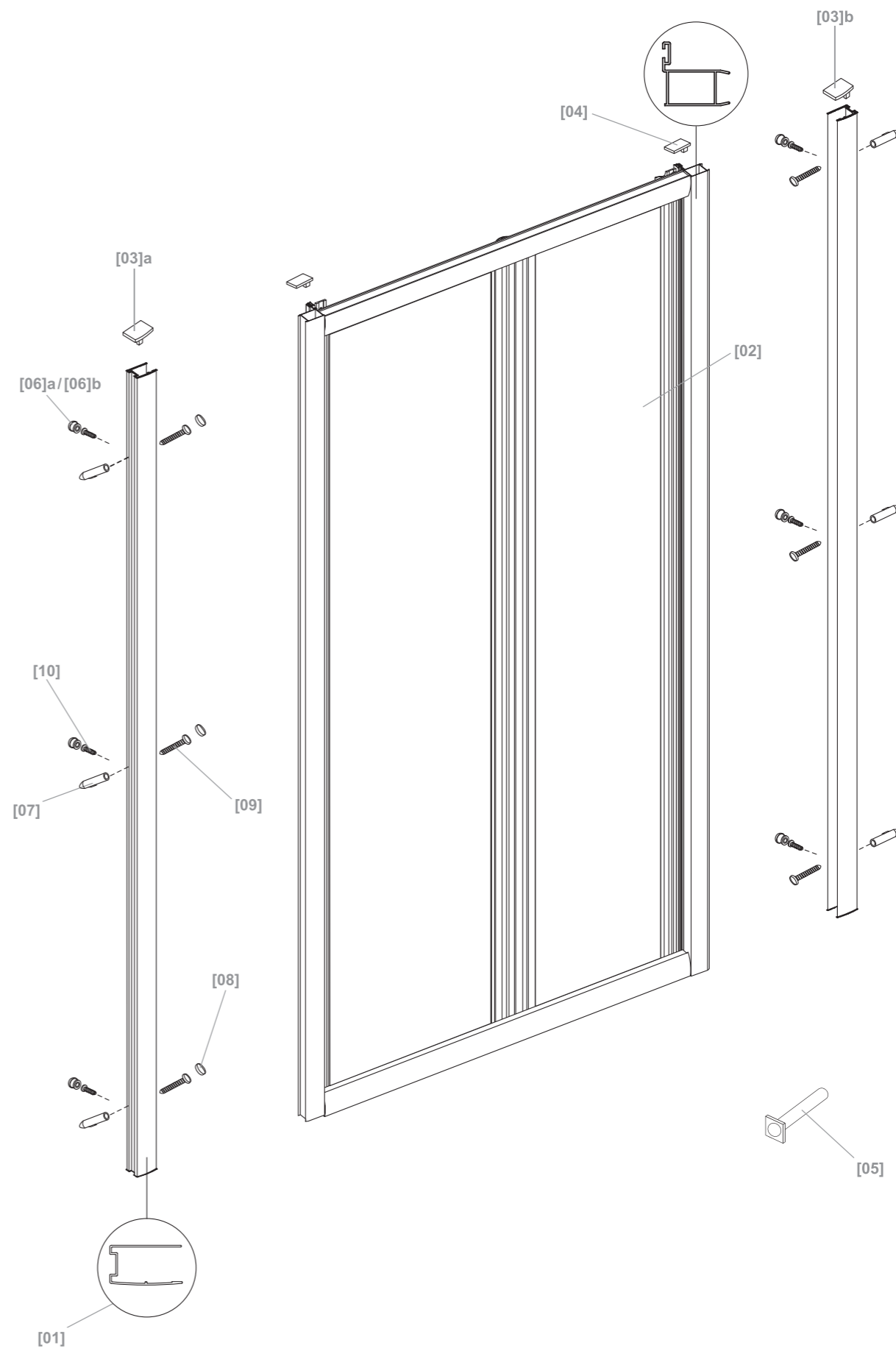



01

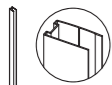

[01] x 1



[07] x 3



[09] x 3

EN Assembly    FR Assemblage    PL Montaż    DE Montage    RU Сборка  
 RO Asamblare    ES Montaje    PT Montagem    TR Kurulum

Model	R
3663602951704/3663602951711	675-725mm
3663602944362/3663602944386	775-825mm
3663602944379/3663602944393	875-925mm

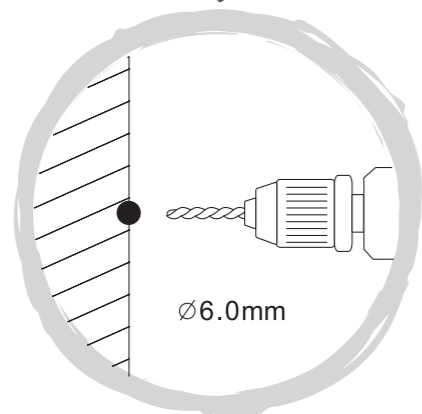
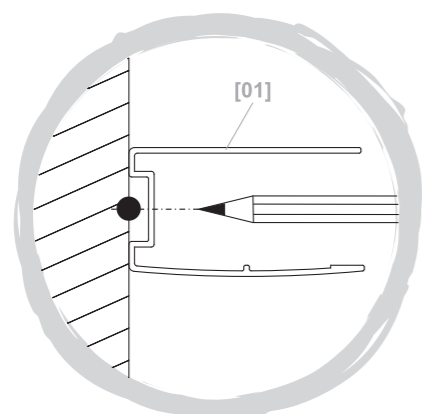

Ø6.0mm

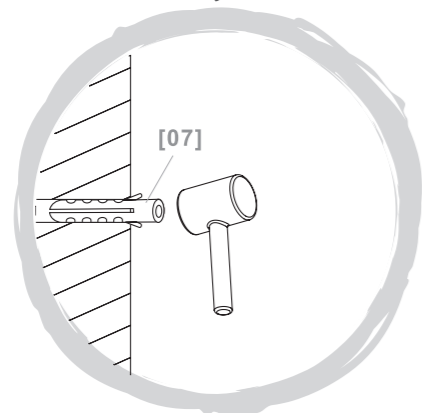

[07]

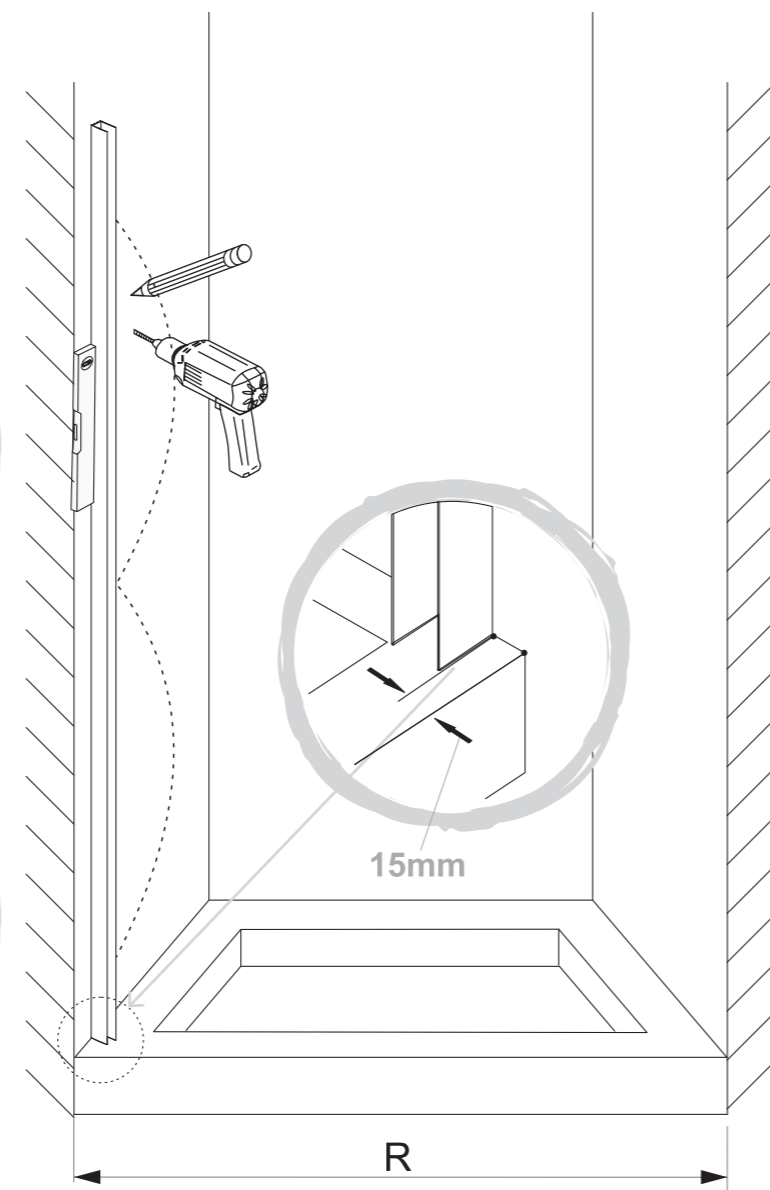
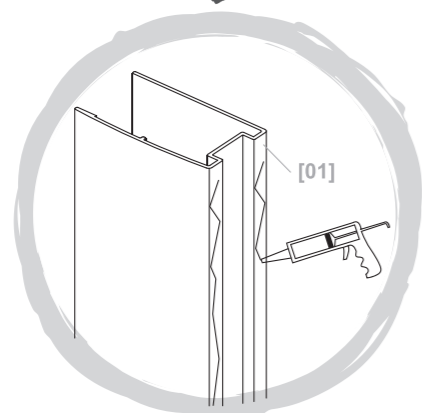

15mm

R

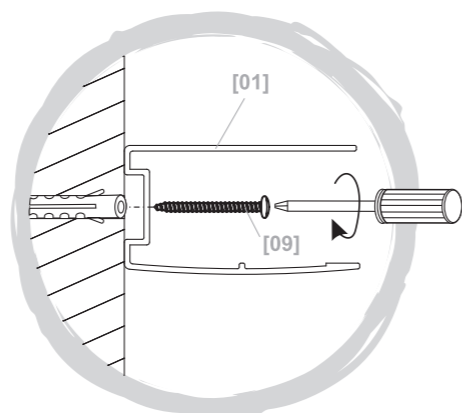

[01]

[09]

02

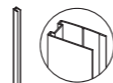

[01] x 1

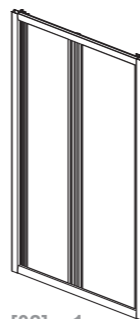

[02] x 1

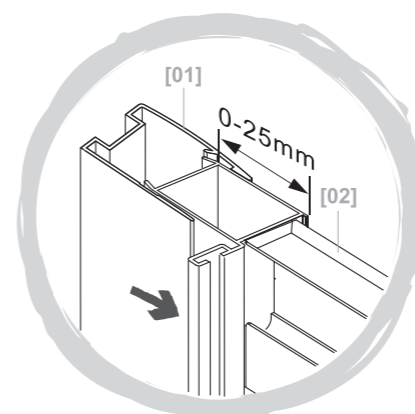

[01]

0-25mm

[02]

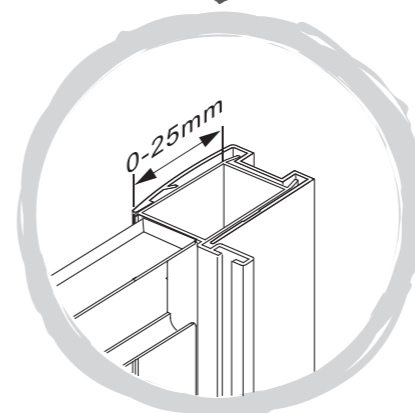
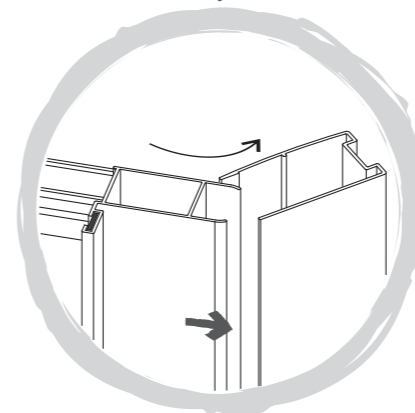
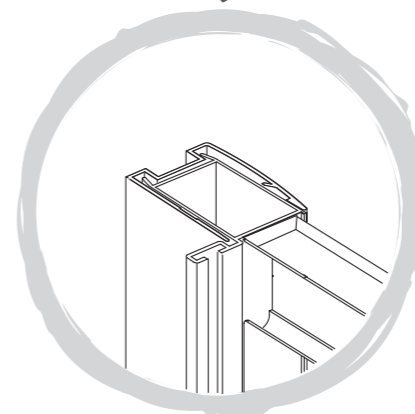

0-25mm

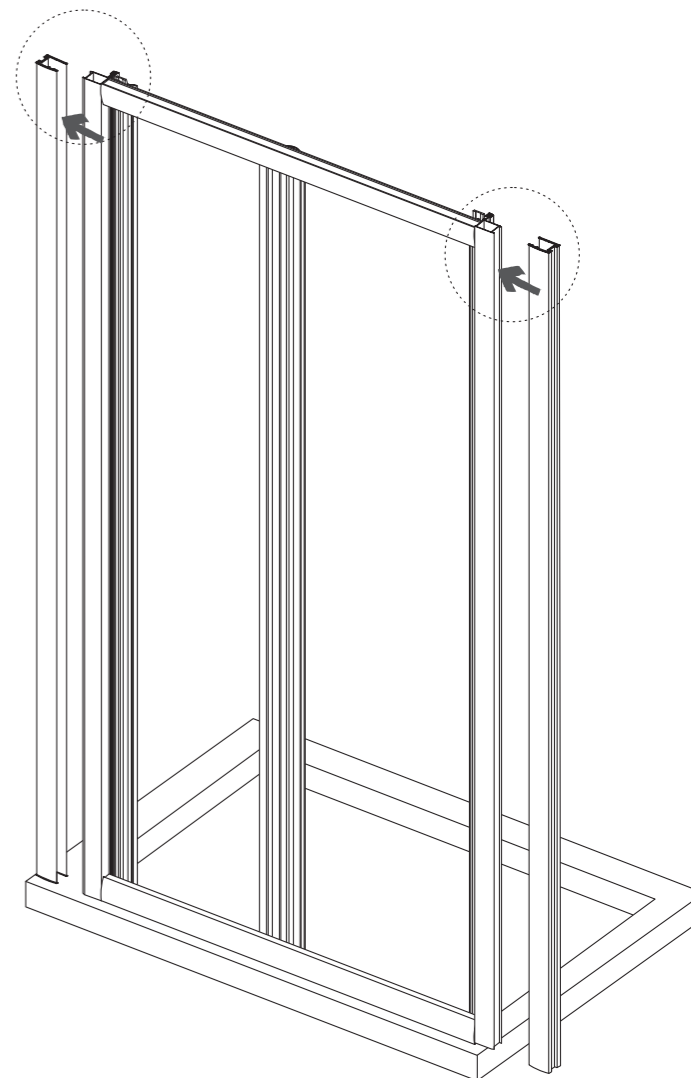

03

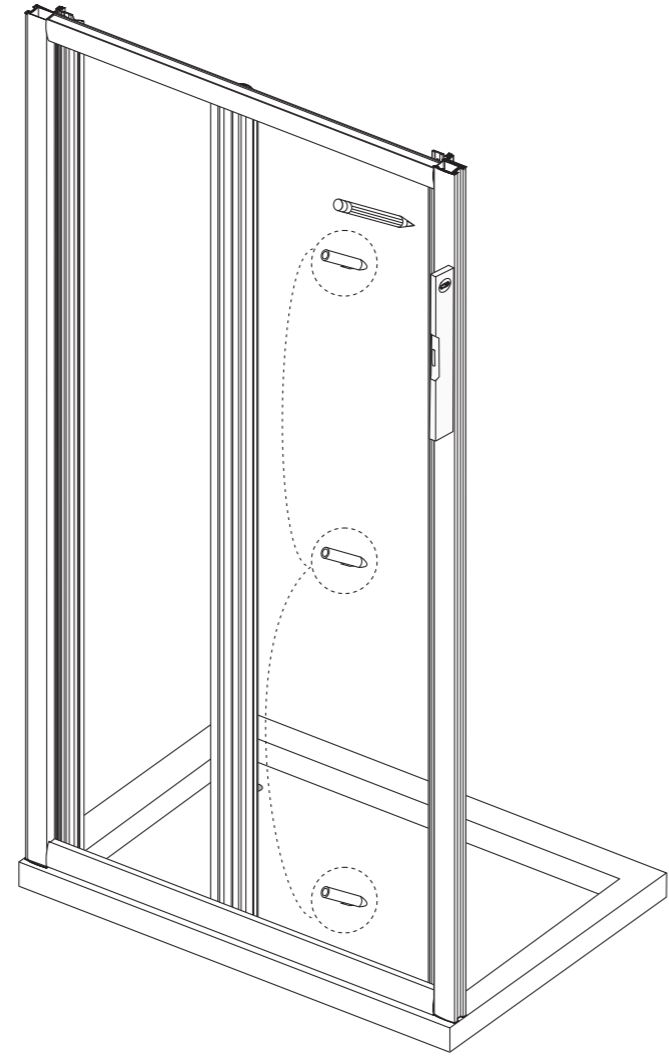
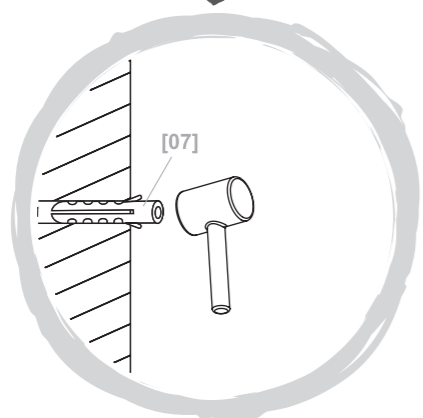
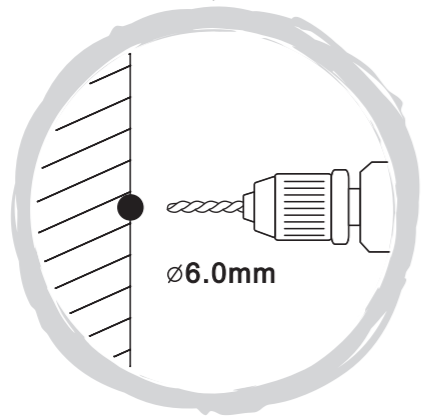
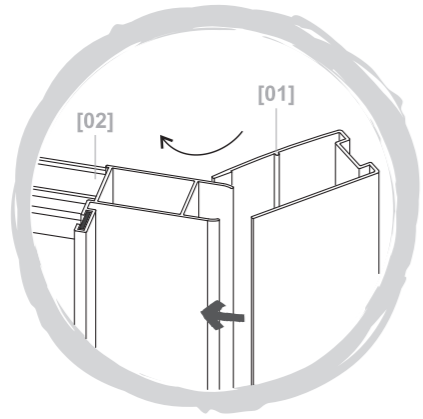
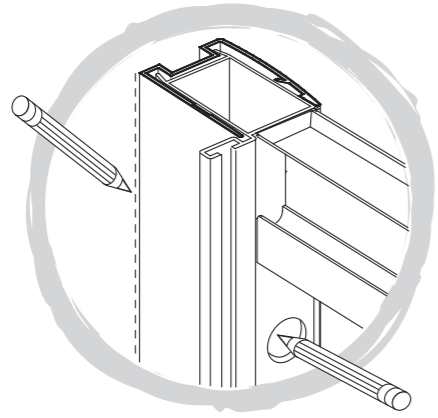

04

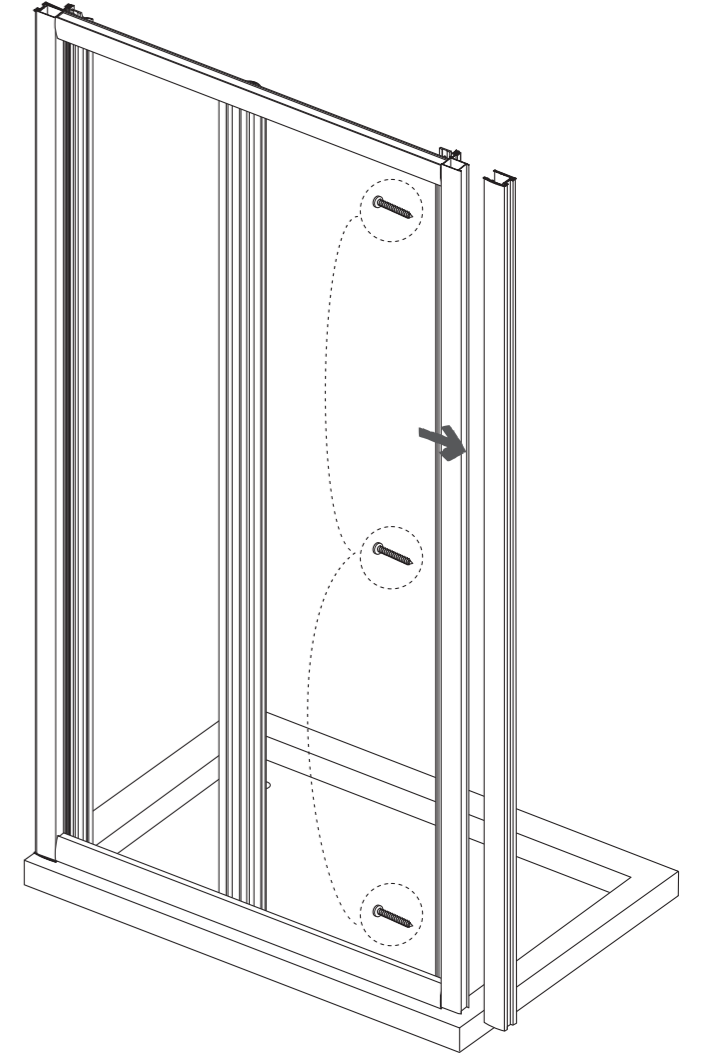
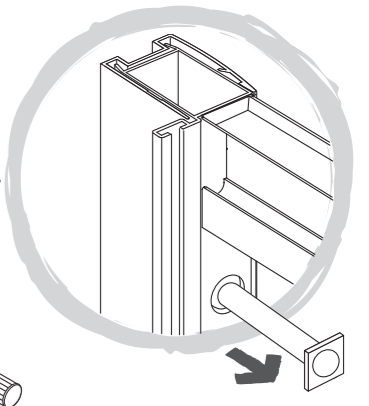
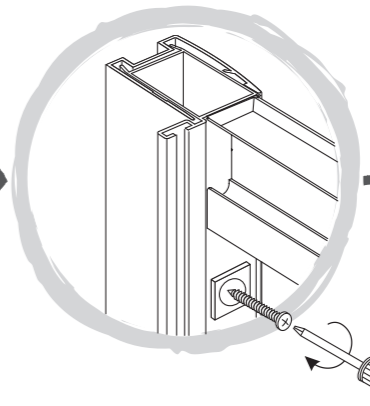
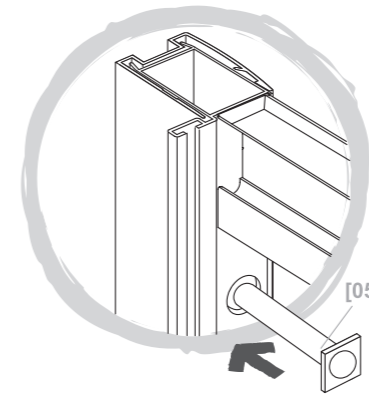
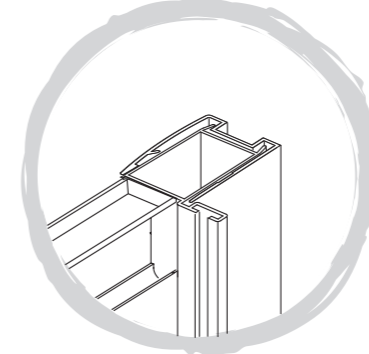
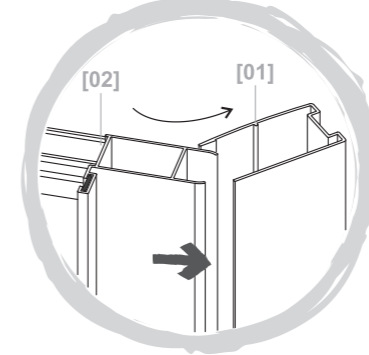
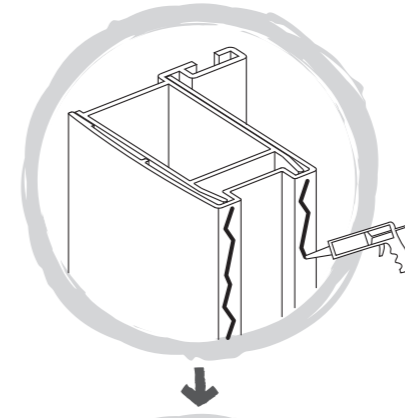
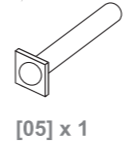

# 05

[06]a x 6

[06]b x 6

[08] x 3

[10] x 6  
(ST3.5 x 8mm)

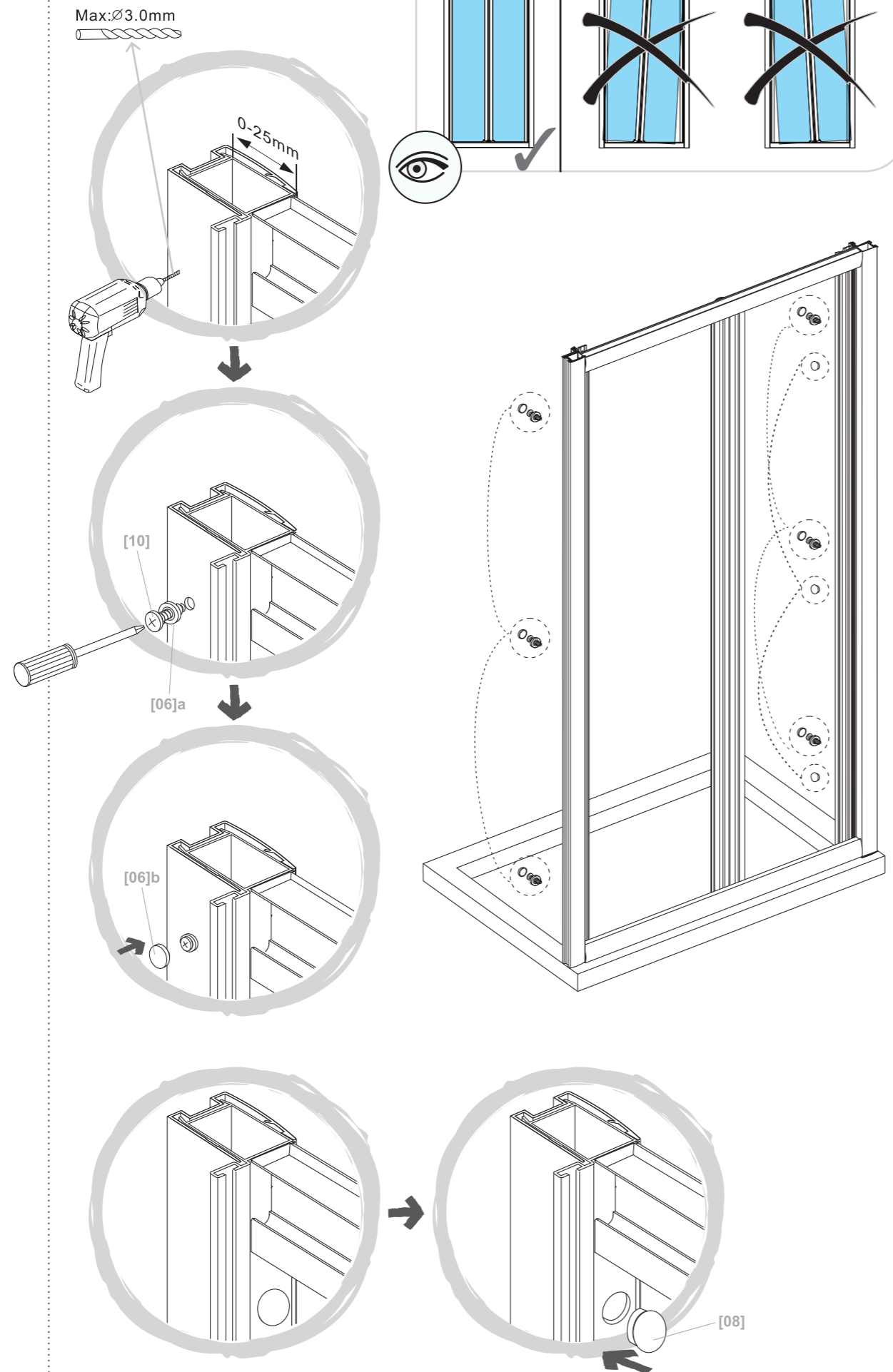

8

# 06

[03]a x 1

[03]b x 1

[04] x 2

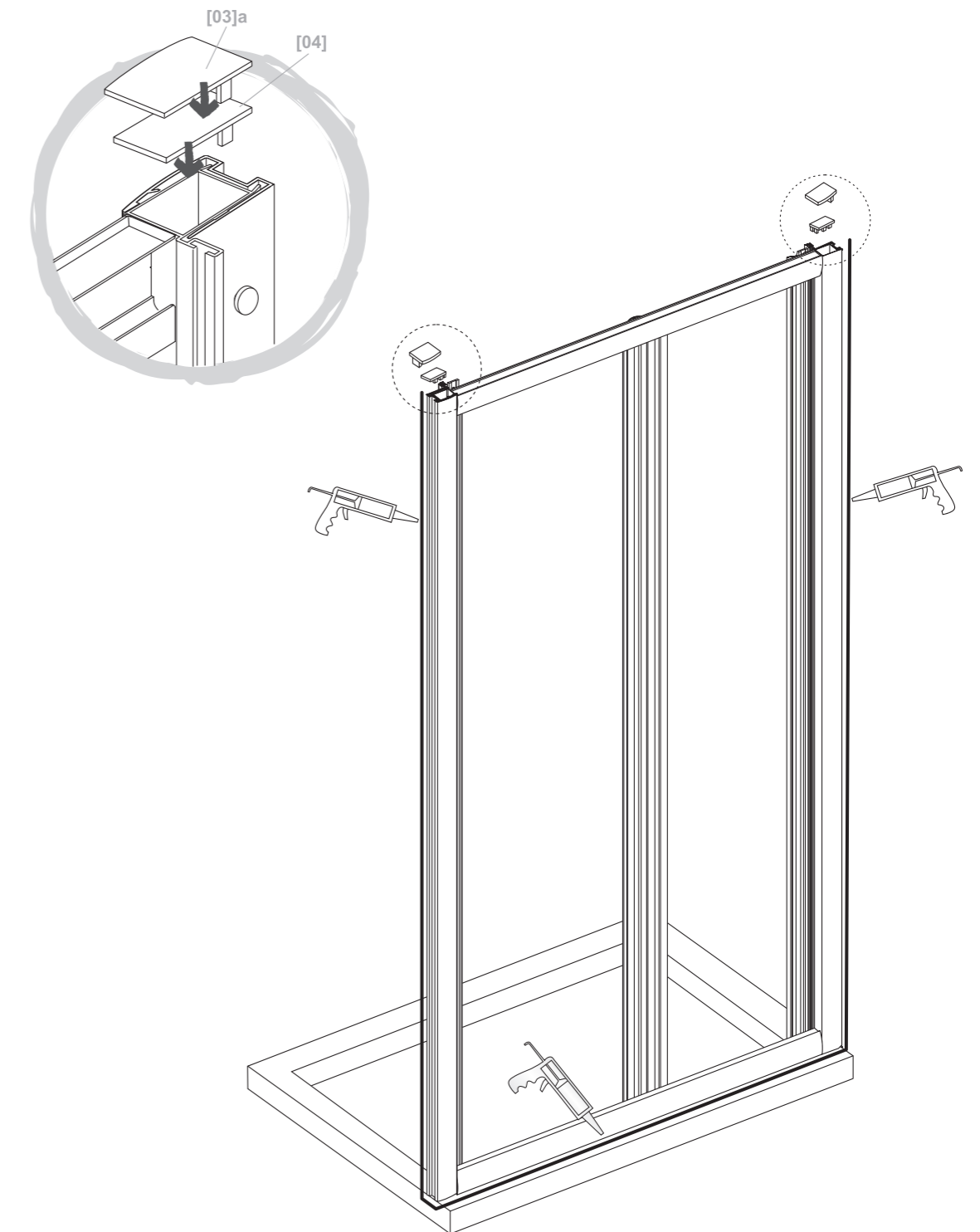

9

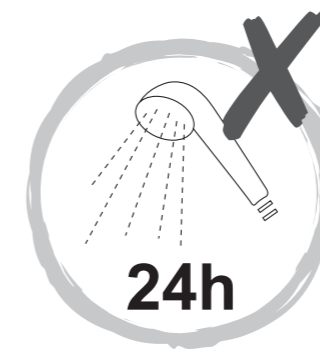

- EN Do not use the shower for at least 24 hours in order to allow the silicone sealant to cure fully.
- FR N'utilisez pas la douche pendant au moins 24 heures afin de permettre à l'agent d'étanchéité à base de silicone de sécher entièrement.
- PL Po zakończeniu montażu, nie używaj brodzika prysznicowego przez co najmniej 24 godziny, aby umożliwić pełne osadzenie się uszczelnacza silikonowego.
- DE Die Duschwanne mindestens 24 Stunden nicht benutzen, damit die Silikonversiegelung vollständig abbinden kann.
- RUS Не используйте душевой поддон минимум 24 часа, чтобы силиконовый герметик полностью застыл.

- RO Nu utilizați cădița de duș timp de cel puțin 24 de ore, pentru a permite agentului de etanșare din silicon să etanșeze pe deplin.
- ES No utilice el plato de ducha durante al menos 24 horas para dejar que el sellado de silicona se endurezca del todo.
- PT Não use a base de chuveiro durante, pelo menos, 24 horas, de modo a permitir que o vedante de silicone assente por completo.
- TR Silikon dolgunun tam olarak kurumasını sağlamak için duş teknesini en az 24 saat kullanmayın.

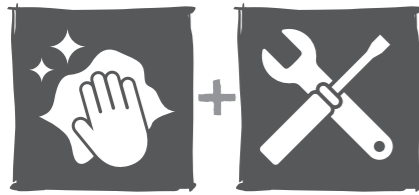

- EN Care & maintenance
- PL Pielęgnacja i konserwacja
- RUS Уход и обслуживание
- ES Cuidados y Mantenimiento
- TR Bakım ve Onarım
- FR Entretien et maintenance
- DE Pflege und Wartung
- RO Îngrijire și întreținere
- PT Cuidados e manutenção

10

EN

## The golden rules for care

**NOTE:** Use warm soapy water and a soft damp cloth to keep the glass clean. Wipe dry with a clean cloth. Scourers, abrasives and chemical cleaners can damage the glass and pattern, and should not be used.

In hard water areas, insoluble lime salts may be deposited on the glass. If this is allowed to build up it becomes increasingly difficult to remove and looks unsightly. Regular cleaning will minimize this effect.

- Do not attempt to cut the glass.
- Do not strike the glass with hard or pointed items.
- Regularly check moving parts such as rollers and hinges to ensure they are secure and adjusted correctly. Tighten and adjust where required. Also check all sealed joints to ensure seal has not deteriorated. Re-seal if required.

FR

## Les règles d'or pour l'entretien

**REMARQUE :** Utilisez de l'eau tiède savonneuse et un chiffon doux humide pour garder la vitre propre. Si nécessaire, vous pouvez utiliser un produit pour vitres. Grattoirs, abrasifs et nettoyeurs chimiques peuvent endommager la vitre et le motif, et ne doivent ainsi pas être utilisés.

Dans les zones dont l'eau est dure, un dépôt de calcaire peut se former sur la vitre. Si vous le laissez s'accumuler, il deviendra de plus en plus difficile à enlever, et sera inesthétique. Un nettoyage régulier permet de réduire cet effet.

- Ne tentez pas de découper la vitre.
- Ne cognez pas la vitre avec des objets durs ou pointus.
- Vérifiez régulièrement les pièces mobiles telles que les rouleaux et charnières afin de vous assurer qu'elles sont solidement fixées et correctement réglées. Serrez et ajustez-les lorsque nécessaire. Vérifiez également tous les joints scellés afin de vous assurer de l'intégrité de l'étanchéité. Scellez à nouveau au besoin.

PL

## Zasady bezpiecznego użytkowania

**INFORMACJA:** Użyj szmatki z ciepłą mydlaną wodą do czyszczenia szyb. Nie należy używać do czyszczenia ostrych zmywaków oraz szorujących lub chemicznych środków czyszczących, ponieważ mogą one uszkodzić szklaną powierzchnię lub wzór na szkło.

W twardej wodzie, nierozpuszczalne sole wapna mogą odkładać się na szybie. Jeśli nagromadzi się ich duża ilość, wówczas stają się one bardzo trudne do usunięcia. Regularne czyszczenie zminimalizuje ten efekt.

- Nie przecinaj szyb.
- Nie uderzaj w szyby twardymi lub spiczastymi przedmiotami.
- Regularnie sprawdzaj ruchome części, takie jak rolki i zawiasy, aby upewnić się, że są one bezpieczne i właściwie ustawione. Dokręć i wyreguluj je w razie potrzeby. Dodatkowo sprawdzaj wszystkie uszczelnione złącza, aby upewnić się, że uszczelnienie nie uległo pogorszeniu. Ponownie uszczelnij w razie potrzeby.

DE

## Die goldenen Regeln der Pflege

**HINWEIS:** Zum Reinigen des Glases warme Seifenlauge und einen weichen, feuchten Lappen benutzen. Mit einem trockenen Lappen trockenwischen. Scheuerschwämme, Scheuermittel und chemische Reiniger können das Glas und die Musterung angreifen und sollten daher nicht benutzt werden.

In Gebieten mit hartem Wasser können sich Kalkablagerungen am Glas bilden. Wenn diese nicht beseitigt werden und sich immer weiter Kalk ablagert, wird es umso schwieriger, die Kalkreste zu entfernen. Nach einiger Zeit wirken diese verkalkten Stellen unansehnlich. Durch regelmäßiges Reinigen kann dem vorgebeugt werden.

- Nicht das Glas anschneiden.
- Nicht mit harten oder spitzen Gegenständen gegen das Glas stoßen.
- Bewegliche Teile wie Rollen und Scharniere regelmäßig auf festen Sitz und richtige Justage überprüfen. Ggf. nachstellen und nachziehen. Außerdem alle versiegelten Übergänge prüfen, um festzustellen, ob die Dichtungen noch intakt sind. Ggf. nachdichten.

RUS

## золотых правила для постоянного использования

**ПРИМЕЧАНИЕ.** Для очистки стекла используйте воду с мылом и мягкую влажную тряпку. Вытрите насухо чистой тряпкой. Не используйте металлические мочалки, абразивные материалы и химические чистящие средства, поскольку они могут повредить стекло и орнамент.

В регионах с жесткой водой на стекле может скапливаться нерастворимый известковый налет. Со временем налет затвердевает и приобретает неприятный вид. Регулярная очистка поможет избежать этого явления.

- Не пытайтесь резать стекло.
- Не ударяйте по стеклу твердыми или острыми предметами.
- Регулярно проверяйте движущиеся детали, чтобы убедиться, что они зафиксированы и правильно отрегулированы. Если необходимо – зафиксируйте и отрегулируйте. Также проверяйте все уплотненные соединения, чтобы убедиться в том, что уплотнение не повреждено. При необходимости уплотните повторно.

11

RO

## Cele reguli de aur pentru întreținere

**NOTĂ:** Utilizați apă caldută cu detergent și o cârpă moale pentru a menține geamul curat. Uscați ștergând cu o cârpă curată. Bureții abrazivi, produsele de curățat abrazive și chimice pot avaria sticla și aspectul acesteia, și nu ar trebui utilizate.

În zone cu apă dură, săruri insolubile de calcar se pot acumula pe sticlă. Dacă acestea sunt lăsate să se depoziteze, aceste acumulări pot deveni extrem de greu de îndepărtat și vor arăta neaspectuos. Curățarea periodică va minimiza acest efect.

- Nu încercați să tăiați sticla.
- Nu loviți sticla cu articole ascuțite sau dure.
- Verificați periodic piesele mobile precum roțile și balamalele pentru a vă asigura că sunt sigure și reglate corect. Strângeți și ajustați unde este nevoie. De asemenea verificați toate izolațiile de etanșizare pentru a vă asigura că nu sunt deteriorate. Reizolați dacă este nevoie.

ES

## Las reglas de oro para su uso y mantenimiento

**NOTA:** Use agua jabonosa tibia y un trapo húmedo suave para mantener el vidrio limpio. Seque con un trapo limpio. Las fibras, los limpiadores abrasivos y los químicos pueden dañar el vidrio y el dibujo, por lo que no deben usarse.

En zonas de agua dura, las sales insolubles de cal pueden depositarse en el vidrio. Si se permite que se acumulen será cada vez más difícil retirarlas y se verá desagradable. La limpieza regular minimizará este efecto.

- No intente cortar el vidrio.
- No golpee el vidrio con artículos duros o puntiagudos.
- Compruebe con regularidad las partes móviles, como las ruedas y bisagras, para asegurarse de que están correctamente ajustadas. Apriételes y ajústelas cuando sea necesario. Compruebe también las juntas selladas para asegurarse de que el sellado no se ha deteriorado. Vuelva a sellarlo si fuera necesario.

PT

## As regras de ouro para os cuidados

**NOTA:** Utilize água morna com sabão e um pano macio húmido para manter o vidro limpo. Limpe com um pano seco. Esfregões, substâncias abrasivas e substâncias químicas podem danificar o vidro e o padrão e não devem ser utilizados.

Em zonas de água calcária, poderão depositar-se resíduos insolúveis no vidro. Se se forem acumulando, torna-se cada vez mais difícil removê-los e o vidro torna-se inestético. Uma limpeza regular minimiza este efeito.

- Não tente cortar o vidro.
- Não bata no vidro com objetos rígidos ou pontiagudos.
- Verifique regularmente as peças móveis, como os roletes e as dobradiças, para garantir que estão devidamente fixos e ajustados. Aperte e ajuste sempre que necessário. Verifique igualmente se as uniões vedadas não apresentam sinais de deterioração. Vede novamente, se necessário.

TR

## Kullanım halindeyken altın kural

**NOT:** Camı temiz tutmak için ılık sabunlu su ve yumuşak nemli bir bez kullanın. Temiz bir bezle kurulayın. Çözücüler, aşındırıcılar ve kimyasal temizleyiciler cama ve dokusuna zarar vereceğinden kullanılmamalıdır.

Suyu sert olan bölgelerde, çözünmeyen kireç tuzları camın üzerinde birikebilir. Bunun birikmesine izin verilirse çıkarılması giderek daha zor bir hal alır ve göze hoş görünmez. Düzenli temizlik bu etkiyi azaltır.

- Camı kesmeye çalışmayın.
- Cama sert veya sivri uçlu nesnelere vurmayın.
- Makara ve mafsal gibi hareketli parçaları düzenli olarak kontrol ederek sağlam ve ayarlarının doğru olduğundan emin olun. Gerektiğinde sıkın ve ayarlayın. Ayrıca contada çürüme, bozulma olmadığından emin olmak için tüm sızdırmazlık noktalarını kontrol edin. Gerekirse sızdırmazlığı yeniden sağlayın.